



VR 75

Field Service Regulator

High pressure first-cut regulator, ideal for use in multi-stage pressure reduction installations.

DESCRIPTION

The VR 75 regulator is a direct-acting, spring-loaded regulator. The lever system ensures exact outlet pressure and a fast response when the flow rate varies.

KEY BENEFITS

- » Universally applicable gas pressure regulator
- » Easy maintenance
- » EN 334 compliant

Technical Features

Inlet pressure	1.0 - 100 bar
Outlet pressure range	0.5 - 16.0 bar
Accuracy class	AC 20, SG 30 to 50
Operating temperature	-20°C to +60°C
Ambient temperature	-30°C to +60°C (body material)
Acceptable gases	Natural gas, propane, butane, air, nitrogen and all non-corrosive gases.

Sizes & Connections

Sizes	DN 25
Dimension	see table
Flanges	PN16, PN 40 or ANSI 150
Thread	1"-NPT (PS: 100 bar, pumax up to 100 bar)

Materials

Body	Aluminium, DIN EN 573-3
Actuator	Aluminium, DIN EN 573-3
Internal parts	Steel, zinc protected
Seals	NBR rubber/Viton
Diaphragm	NBR rubber, reinforced fabric

Operational Diagram

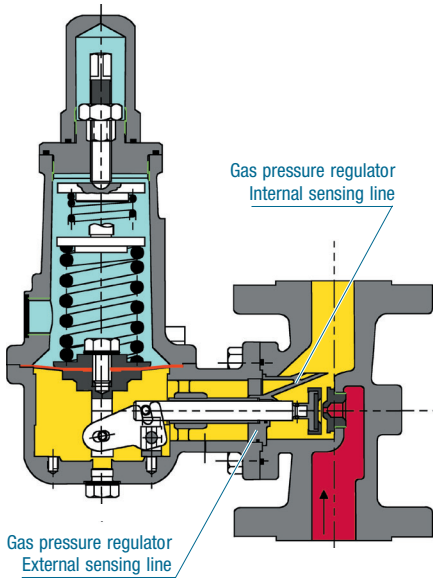

- Inlet Pressure
- Outlet Pressure
- Atmospheric Pressure

OPERATING PRINCIPLE

The VR 75 regulator is a direct-acting, spring-loaded regulator suitable for all non-aggressive gases. The required outlet pressure can be easily set to another command range by adjusting the command variable, or by exchanging the spring.

Due to its spring principle, this type of regulator operates independently of its position.

Flange connections between the diaphragm casing and the actuator body provide various installation possibilities.

The orifice and regulating unit can be exchanged without removing the actuator body from the installation.

A ventilation line must be connected to the regulator's ventilation connection.

Accuracy Class AC and Closing Pressure Class SG

Admissible Inlet Pressure Range (bar)	Inlet Pressure Change per Setting (bar)	Outlet Pressure Range (bar)	Accuracy Class	Closing Group	Orifice Ø (mm)
1 – 100	14	0.45 – 16	AC 20	SG 30	3.2 (1/8")
1 – 70.	10	0.45 – 16	AC 20	SG 30	4.7 (3/16")
2 – 40	10	0.45 – 16	AC 20	SG 30	6.3 (1/4")
1 – 25	4	0.45 – 1.0	AC 20	SG 50	8.0 (5/16")
1 – 25	10	1 – 16	AC 20	SG 30	8.0 (5/16")
1 – 16	2	0.45 – 2	AC 20	SG 50	10.0 (3/8")
1 – 6	2	0.45 – 1	AC 20	SG 50	12.5 (1/2")

OUTLET PRESSURE RANGE

Spring Range	Spring Code	Colour	Wire Ø (mm)
0.45 – 0.84 bar	955-201-13	yellow	3.8
0.70 – 1.75 bar	955-201-14	silver	4.5
0.70 – 7 bar	955-200-80	dark green	7.0
1.40 – 4.20 bar	955-200-36	white	6.3
3.50 – 8.75 bar	955-201-56	brown	8.0
7 – 16 bar	955-201-57	grey	9.5

FLOW CAPACITY

The VR 75 regulator can be fitted with an orifice of various sizes in order to match the capacity requirements. Large size orifices offer extra-large flow rate possibilities, but are not recommended for high inlet pressures.

Capacity Tables

Outlet Pressure (bar)	Inlet Pressure (bar)	Capacities at Standard Conditions (m³/h)					
		Orifice size					
		1/2" 12 mm	3/8" 10 mm	5/16" 8 mm	1/4" 6 mm	3/16" 5 mm	1/8" 3 mm
0.5	1	65	55	43	33	19	8
	2	144	113	86	65	37	17
	3	210	170	136	92	53	24
	4	275	220	166	120	69	31
	5	335	272	204	145	82	38
	6	392	322	240	170	98	45
	8	•	420	312	220	125	57
	10	•	515	380	270	153	70
	12	•	600	446	320	180	82
	16	•	770	575	420	235	105
1	20	•	•	700	515	290	130
	25	•	•	850	625	350	160
	2	128	102	77	58	32	15
	4	275	220	166	120	69	31
	6	392	322	240	170	98	45
	10	•	515	380	270	153	70
	16	•	770	575	420	235	105
	20	•	•	700	515	290	130
	25	•	•	850	625	350	160
	30	•	•	•	750	420	190
2	35	•	•	•	850	480	225
	40	•	•	•	950	550	250
	50	•	•	•	•	680	310
	64	•	•	•	•	850	390
	3	190	155	110	82	48	21
	4	265	217	160	112	65	29
	6	392	322	240	170	98	45
	10	•	515	380	270	153	70
	16	•	770	575	420	235	105
	20	•	•	700	515	290	130
25	•	•	850	625	350	160	
30	•	•	•	750	420	190	
35	•	•	•	850	480	225	
40	•	•	•	950	550	250	
50	•	•	•	•	680	310	
64	•	•	•	•	850	390	

Outlet Pressure (bar)	Inlet Pressure (bar)	Capacities at Standard Conditions (m ³ /h)					
		Orifice size					
		1/2" 12 mm	3/8" 10 mm	5/16" 8 mm	1/4" 6 mm	3/16" 5 mm	1/8" 3 mm
4	5	300	250	180	125	72	32
	6	385	310	225	157	90	41
	10	•	515	380	270	153	70
	16	•	770	575	420	235	105
	20	•	•	700	515	290	130
	25	•	•	850	625	350	160
	30	•	•	•	750	420	190
	40	•	•	•	950	550	250
	50	•	•	•	•	680	310
	64	•	•	•	•	850	390
80	•	•	•	•	•	480	
100	•	•	•	•	•	600	
6	8	•	380	270	190	105	48
	10	•	480	360	250	143	65
	12	•	590	430	320	176	80
	16	•	770	575	420	235	105
	20	•	•	700	515	290	130
	25	•	•	850	625	350	160
	30	•	•	•	750	420	190
	40	•	•	•	950	550	250
	50	•	•	•	•	680	310
	64	•	•	•	•	850	390
80	•	•	•	•	•	480	
100	•	•	•	•	•	600	
8	10	•	440	330	230	130	58
	12	•	560	410	290	170	70
	16	•	770	560	420	235	105
	20	•	•	700	515	290	130
	25	•	•	850	625	350	160
	30	•	•	•	750	420	190
	35	•	•	•	850	480	225
	40	•	•	•	950	550	250
	50	•	•	•	•	680	310
	64	•	•	•	•	850	390
80	•	•	•	•	•	480	
100	•	•	•	•	•	600	
10	12	•	•	360	240	140	64
	16	•	•	520	380	210	95
	20	•	•	680	515	275	122
	25	•	•	850	625	350	158
	30	•	•	•	750	420	190
	35	•	•	•	850	480	225
	40	•	•	•	950	550	250
	50	•	•	•	•	680	310
	64	•	•	•	•	850	390
	80	•	•	•	•	•	480
90	•	•	•	•	•	540	
100	•	•	•	•	•	600	
16	18	•	•	530	360	200	90
	20	•	•	620	430	240	105
	25	•	•	815	580	320	140
	30	•	•	•	750	400	175
	35	•	•	•	850	450	210
	40	•	•	•	950	540	240
	50	•	•	•	•	680	310
	64	•	•	•	•	850	390
	70	•	•	•	•	860	430
	80	•	•	•	•	•	480
90	•	•	•	•	•	540	
100	•	•	•	•	•	600	

Standard conditions:

- Absolute pressure of 1.013 bar
- Temperature of 15°C

Correction factor for non-natural gas applications:

The flow rates are indicated for a 0.6 specific gravity gas.

To determine the volumetric flow rate for gases other than natural gas, multiply or calculate the values in the capacity tables using the sizing equations with a correction factor.

The table below lists correction factors for some common gases:

Gas type	Specific gravity	Correction factor
Air	1.00	0.77
Butane	2.01	0.55
Carbon dioxide (dry)	1.52	0.63
Carbon monoxide (dry)	0.97	0.79
Natural gas	0.60	1.00
Nitrogen	0.97	0.79
Propane	1.53	0.63
Propane-Air mix	1.20	0.71

Specific gravity or relative density (air = 1, non-dimensional value)

Use the following formula to calculate the correction factor for gases not listed above. In the formula, d is the specific gravity of the gas.

$$\text{Correction factor} = \sqrt{\frac{0.6}{d}}$$

AVAILABLE CONFIGURATIONS

The VR 75 regulator can be fitted with either an internal or an external sensing line (see the cross-sections).

A special configuration is available for pressure relief and throttling backpressure applications.

Reference numbers:

- » VR 75-RE Regulator with internal sensing line
- » VR 75-RF Regulator with external sensing line
- » VR 75-ÜE Relief valve with internal sensing line
- » VR 75-ÜF Relief valve with external sensing line

DIMENSIONS (mm)

Note: Both the actuator casing and the breather tap can be turned 90°.

DN Pressure Rate	D	k	d4	f	b	d2	L
DN 25 / PN 16	115	85	68	2	20	14	160
DN 25 / PN 40	115	85	68	2	20	14	160
1" -NPT	•	•	•	•	•	•	150

(*) ISO 228/1

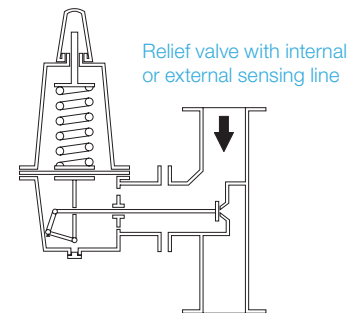
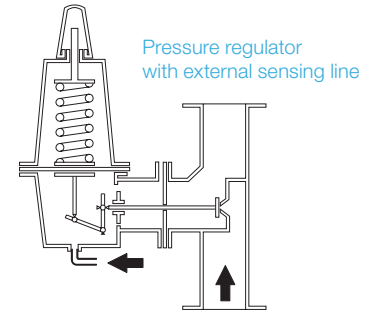
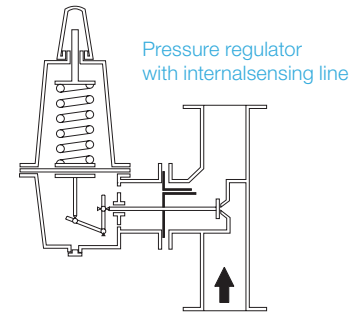
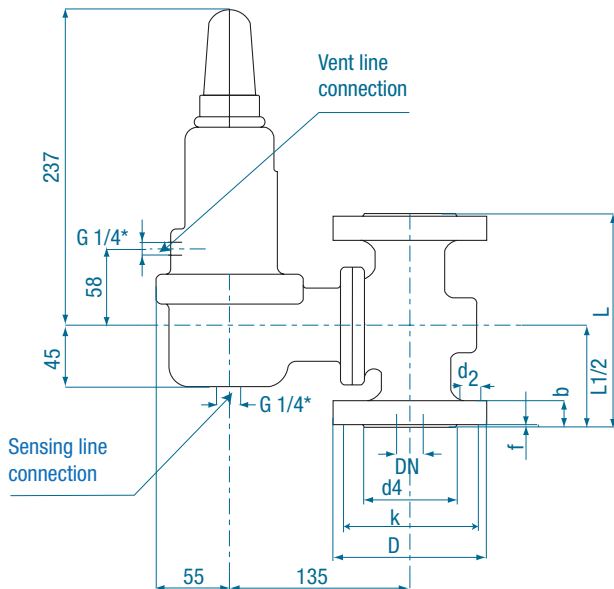

Information to be specified when ordering:

- » Regulator type code
- » Minimum and maximum inlet pressures
- » Outlet pressure range
- » Outlet pressure setting



Our company is the world's leading provider of smart metering, data collection and utility software systems, with over 8,000 utilities worldwide relying on our technology to optimize the delivery and use of energy and water.

To realize your smarter energy and water future, start here: www.itron.com

For more information, contact your local sales representative or agency:

ITRON GmbH

Hardeckstraße 2
D-76185 Karlsruhe
Germany

Phone: +49-721 5981 0

Fax: +49-721 5981 189